

# A Comparative Study of Constant Speed and Variable Speed Wind Energy Conversion Systems

**Mr. Datkhile S. N.**

*PG Student*

*Department of Electrical Engineering  
SND COE and RC, Nashik*

**Prof. P. C. Tapre**

*Assistant Professor*

*Department of Electrical Engineering  
SND COE and RC, Nashik*

**Prof. C. Veeresh**

*Assistant Professor*

*Department of Electrical Engineering  
SND COE and RC, Nashik*

## Abstract

In the early development of the wind energy, the majority of the wind turbines have been operated at constant speed. Subsequently, the number of variable-speed wind turbines installed in wind farms has increased. In this paper, a comparative study of fixed wind speed and variable wind speed system incorporating permanent magnet synchronous generator has been presented. These two systems are modeled and simulated using Matlab. The PMSG has received a lot of important in wind energy applications, due to their possessions of self-excitation, high efficiency and with a variable-speed operation it has become possible continuously to adapt the rotational speed 'wr' of the wind turbine to the wind speed. The advantage of variable wind speed turbine system is increased the energy captured. The results are presented for the permanent magnet synchronous generator is connected to fixed wind speed and variable wind speed system, The performances of each studied wind generator are evaluated by simulation Work.

**Keywords-** Wind energy conversion system, Variable wind system, Constant speed system, permanent magnet synchronous generator, wind energy

## I. INTRODUCTION

In the recent years there has been an increasing awareness about the climate change (global warming) and the harmful effects of carbon emission. This created a higher demand for clean and sustainable energy source like: wind, solar, biomass, tidal etc. In this context, wind is a particularly attractive option. Electric energy is generated from wind using a wind turbine and an electric generator. The generated energy can be used either for standalone loads or fed into the power grid through an appropriate power electronic converter. The wind energy has experienced the biggest growth in the past few years. This is because wind energy is a pollution-free resource, has an unlimited potential. Wind power is capable of supplying hundreds of megawatts of power, but the main challenge associated with wind energy conversion is the wasted potential wind power due to changing wind conditions. With each change in wind velocity, the system must be corresponding adjusted to its optimum operating point to allow maximum power transfer. Wind energy systems are either fixed-speed or variable-speed wind turbine systems. To form the system unreliable within the variable speed turbine. There reliability is improved considerably by employing a direct driven PMSG.

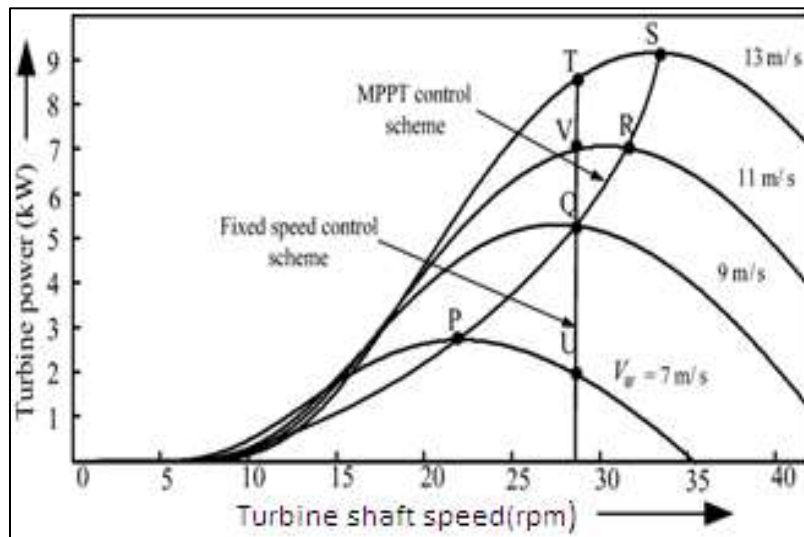

Fig. 1: Turbine power vs turbine speed for different wind velocities.

At a particular wind velocity, the amount of power generated by the turbine depends upon the speed of the turbine, turbine parameters, and the air density. The air density is usually assumed to be constant. Turbine parameters are determined by its design and are constant. Therefore, for a fixed blade pitch angle turbine, the output power of the turbine is mainly dependent upon the turbine speed. The characteristics shift as the wind velocity changes.

The fig.1. shows the turbine power versus turbine speed for different wind velocity like 7 m/s, 9 m/s, 11 m/s, 13 m/s etc. the energy from the wind extracted by using a constant speed wind energy conversion system (WECS). This extracted energy converted in to electrical energy to the generator and this generated power is fed into the grid or standalone load. The main drawback of overall system its poor efficiency because it cannot track maximum power. As the wind velocity change, this situation is dissipated by segment T-V-Q-U in the above figure. Let the constant speed system be set to correspond to MPP “Q” for a wind velocity of 9 m/s. This would result in the system running at points U, V, and T for be set to correspond to MPP “Q” for a wind velocity of 9 m/s. This would result in the system running at points U, V, and T for other wind velocities, which are far away from the actual MPP points P, R, and S, respectively, for the corresponding wind velocities. With the advent of high speed, high power converters, variable-speed operation of the WECS has now become possible and the system can be made to run at a speed corresponding to MPP for the current wind velocity,, i.e., the system, represented by Fig.1 can run at P, Q, R, and S. The amount of energy captured from the wind in this case is much higher than a fixed speed system.

## II. WIND POWER EQUATION AND PMSG COORDINATE SYSTEM

The output power of a wind turbine is given by the equation:

$$P = \frac{1}{2} \rho \pi R^2 V^3 \cdot C_p \dots \dots \dots (1)$$

Where,

- $\rho$  is the air density,
- R the turbine radius,
- V the wind speed and
- $c_p$  the power coefficient.

The power coefficient is defined as the ratio of turbine power to wind power, and it is a function of the tip speed ratio ( $\lambda$ ) as well as the blade pitch angle ( $\beta$ ). For the following  $\beta$  is considered constant, as it changes only when full load is achieved through a feedback control loop that regulates power output.  $\lambda$  is defined as the ratio of turbine speed at the tip of a blade to wind velocity, and given by:

$$\lambda = \frac{W_r R_r}{v} \dots \dots \dots (2)$$

where,

- $W_r$ - is the turbine rotational speed,
- $R_r$ - is the radius of the rotor.

A permanent-magnet wind power system is mainly comprised of permanent-magnet synchronous generator, generator side converter, and grid side converter. In the method, d-q coordinate system spins in the synchronous speed with the q-axis leads d-axis. The stator’s voltage equation can be achieved when the d-axis is set on the rotor’s permanent magnet flux direction.

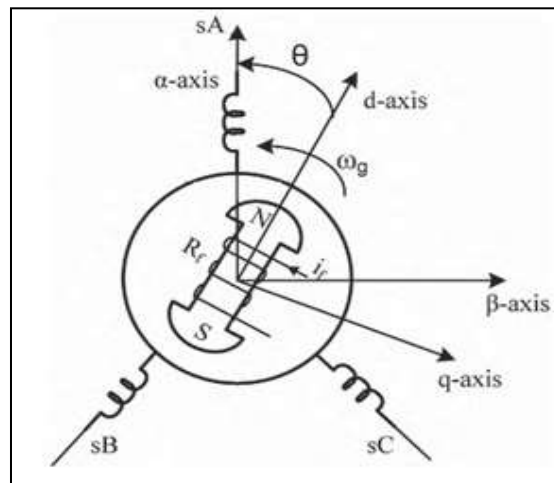

Fig. 2: PMSG coordinate system

In static abc coordinate system, the stator's voltage vector and the flux linkage are

$$u_s = R_s i_s + \frac{d\psi_s}{dt} + \frac{d\psi_f}{dt} \dots\dots\dots(3)$$

$$\psi_s = L_s i_s + \psi_f \dots\dots\dots(4)$$

Where,

' $u_s$ ' is the generator stator voltage vector,

' $R_s$ ' is the generators stator phase resistance,

' $i_s$ ' is the generator stator current vector,

' $\psi_s$ ' is the stators flux linkage,

' $\psi_f$ ' is the rotor's permanent magnet flux linkage,

' $L_s$ ' is the generator's synchronous inductance.

In rotor flux-oriented vector control, the ac permanent magnet synchronous motor stator's voltage, current and flux linkage are decomposed in to permanent magnet base wave excitation axis direction (d-axis) and rotor rotates direction advance 90 degree direction (q-axis). The d-q coordinate system rotates at a synchronous speed  $\omega_r$  as the rotor.

Then the field-oriented stator's voltage equation is

$$u_{sd} = R_s i_{sd} + \frac{d\psi_{sd}}{dt} - \omega_r \psi_{sq} \dots\dots\dots(5)$$

$$u_{sq} = R_s i_{sq} + \frac{d\psi_{sq}}{dt} - \omega_r \psi_{sd} \dots\dots\dots(6)$$

Where,

' $\psi_{sd}$ ' is the stator's d-axis linkage component,

' $\psi_{sq}$ ' is the stator's q-axis flux linkage component,

' $u_{sd}$ ' is the generator's d-axis voltage component,

' $u_{sq}$ ' is the generator's stator q- axis voltage component,

' $i_{sd}$ ' is the generator's stator d-axis current component,

' $i_{sq}$ ' is the generator's stator q-axis current component.

The d-q coordinate system flux linkage is given as

$$\psi_{sd} = L_d i_{sd} + \psi_f \dots\dots\dots(7)$$

$$\psi_{sq} = L_q \dots\dots\dots(8)$$

For surface- mounted permanent magnet synchronous generator, the air gap can be approximated as even. Then

$$L_d = L_q = L_s \dots\dots\dots(9)$$

Combining equation, (3)-(8). We obtain

$$u_{sd} = R_s i_{sd} + L_s \frac{di_{sd}}{dt} - \omega_r L_s i_{sq} \dots\dots\dots(10)$$

$$u_{sq} = R_s i_{sq} + L_s \frac{di_{sq}}{dt} + \omega_r L_s i_{sd} + \omega_s \psi_f \dots\dots\dots(11)$$

From equation (10) and (11), it is shown that the stator's d-axis and q-axis current is not only affected by control voltage  $u_{sd}$  and  $u_{sq}$  but also has relationship with coupling voltage  $-\omega_r L_s i_{sq}$ ,  $\omega_r L_s i_{sd}$  and  $\omega_s \psi_f$ . The coupling voltage is the function of rotation speed  $\omega_r$ , and it will substantially increase when the generator operates at high speed. Under this condition, he coupling voltage component will affect the output of torque current so that the output torque would be inaccurate. As a result, decouple is needed for  $u_{sd}$  and  $u_{sq}$ . Using rotor flux orientation vector control method,  $i_{sd} = 0$ , when the generator is in steady operation. Then the generator's electromagnetic torque is,

$$T_{em} = P \psi_i i_{sq} \dots\dots\dots(12)$$

Where, p- is polar pair.

### III. WIND TURBINE TOPOLOGIES

#### A. Fixed Speed Wind Turbine

In the early 1990s the standard installed wind turbines operated at fixed speed. That means that regardless of the wind speed, the wind turbines rotor speed is fixed and determined by the frequency of the supply grid, the gear ratio and the generator design. It is characteristic of fixed-speed wind turbines that they are equipped with an induction generator (squirrel cage or wound rotor) that is directly connected to the grid, with a soft-starter and a capacitor bank for reducing reactive power compensation. They are designed to achieve maximum efficiency at one particular wind speed. In order to increase power production, the generator of some fixed-speed wind turbines has two winding sets: one is used at low wind speeds (typically 8 poles) and the other at medium and high wind speeds (typically 4–6 poles). Construction of fixed speed wind turbine is simple, robust and reliable. Cost of the electrical part is low.

#### B. Variable Speed Wind Turbine

During the past few years the variable-speed wind turbine has become the dominant type among the installed wind turbines. Variable-speed wind turbines are designed to achieve maximum aerodynamic efficiency over a wide range of wind speeds. With a variable-speed operation it has become possible continuously to adapt (accelerate or decelerate) the rotational speed ' $\omega_r$ ' of the wind turbine to the wind speed  $V$ . This way, the tip speed ratio  $\lambda$  is kept constant at a predefined value that corresponds to the maximum power coefficient. Contrary to a fixed-speed system, a variable-speed system keeps the generator torque fairly constant and the variations in wind are absorbed by changes in the generator speed. The electrical system of a variable-speed wind turbine is more complicated than that of a fixed-speed wind turbine. It is typically equipped with an induction or synchronous generator and connected to the grid through a power converter. The power converter controls the generator speed; that is, the power fluctuations caused by wind variations are absorbed mainly by changes in the rotor generator speed and consequently in the wind turbine rotor speed. The variable wind turbine increases the energy capture. This are improved the power quality and reduced mechanical stress on the wind turbine system.

### IV. SIMULATION OF WIND TURBINE SYSTEM CONNECTED PMSG

The simulation of wind turbine system is connected to Permanent Magnet Synchronous Generator with the help of two mass drive train modal. In this section the performance of the PMSG system is analyzed under constant wind speed profile like 12 m/s. The Waveforms of PMSG output voltage and current are shown in fig.

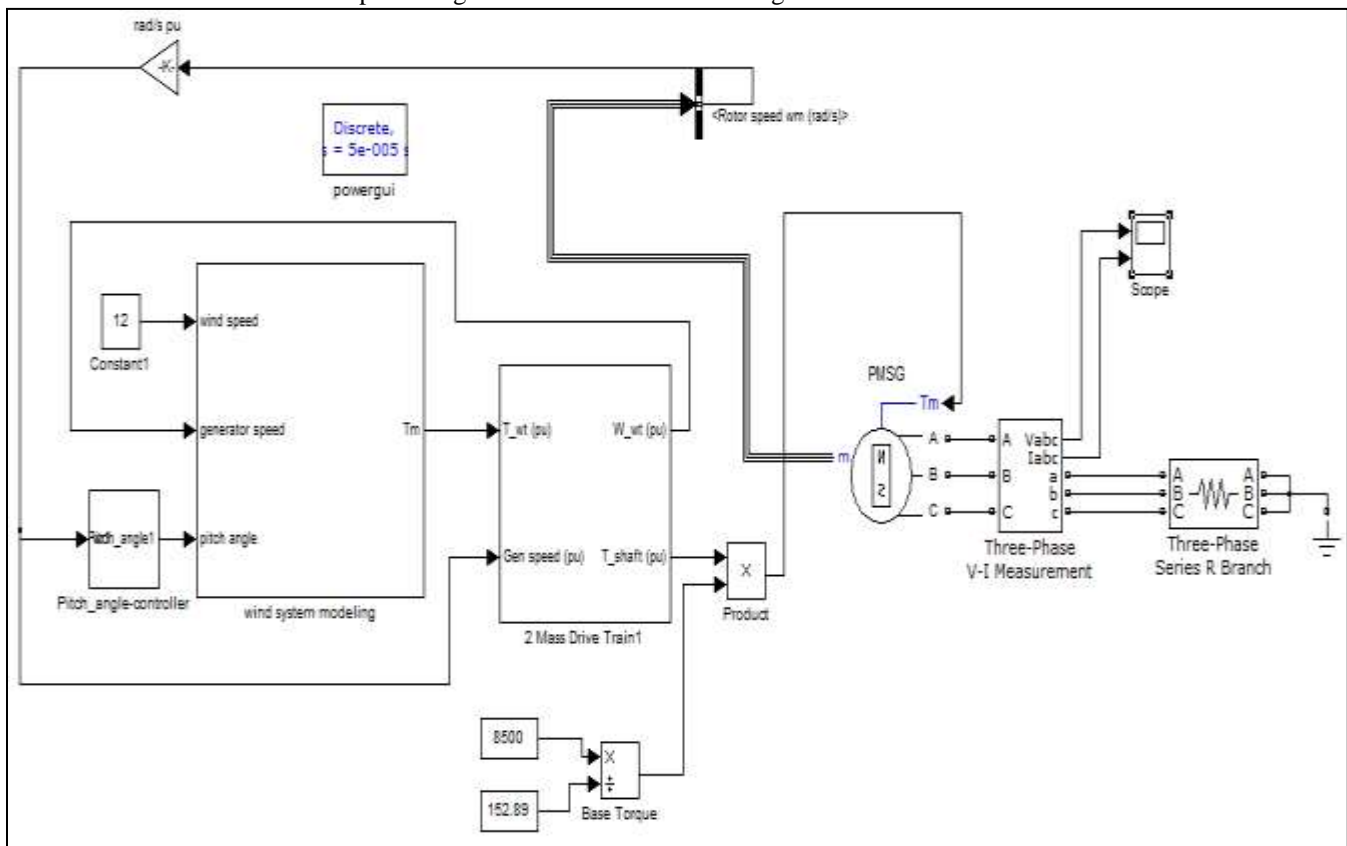

Fig. 3: PMSG connected to constant wind speed profile.

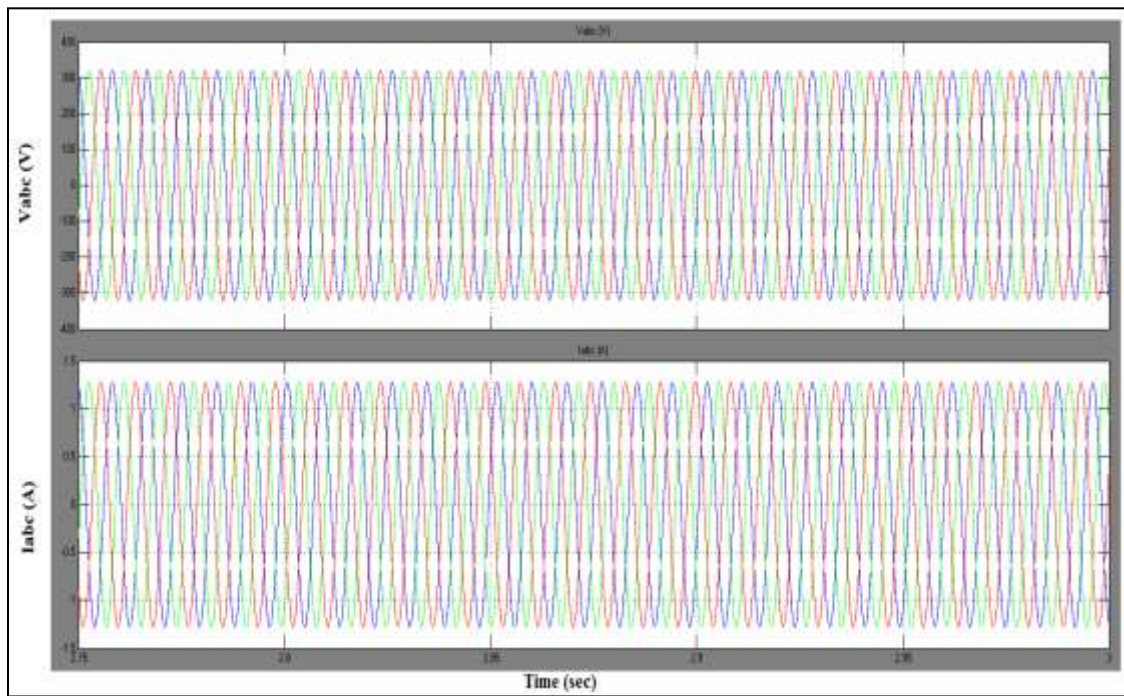

Fig. 4: Output  $V_{abc}$  and  $I_{abc}$  for constant wind speed profile.

In this section the simulation of wind system connected to PMSG for Variable wind speed profile. The wind speed is changed and their corresponding change in magnitudes is given in fig. For 0-5 sec., the wind speed is 12 m/s, for 5-10 sec., the wind speed is 15 m/s, for 10-15 sec., the wind speed is 20 m/s and for 15-20 sec., the wind speed is 22 m/s. This wind speed is taken and system is simulated and it is observed that PMSG produces  $V_{abc}$  and  $I_{abc}$ . When the wind speed changes the output voltage and current will change which is shown in fig.

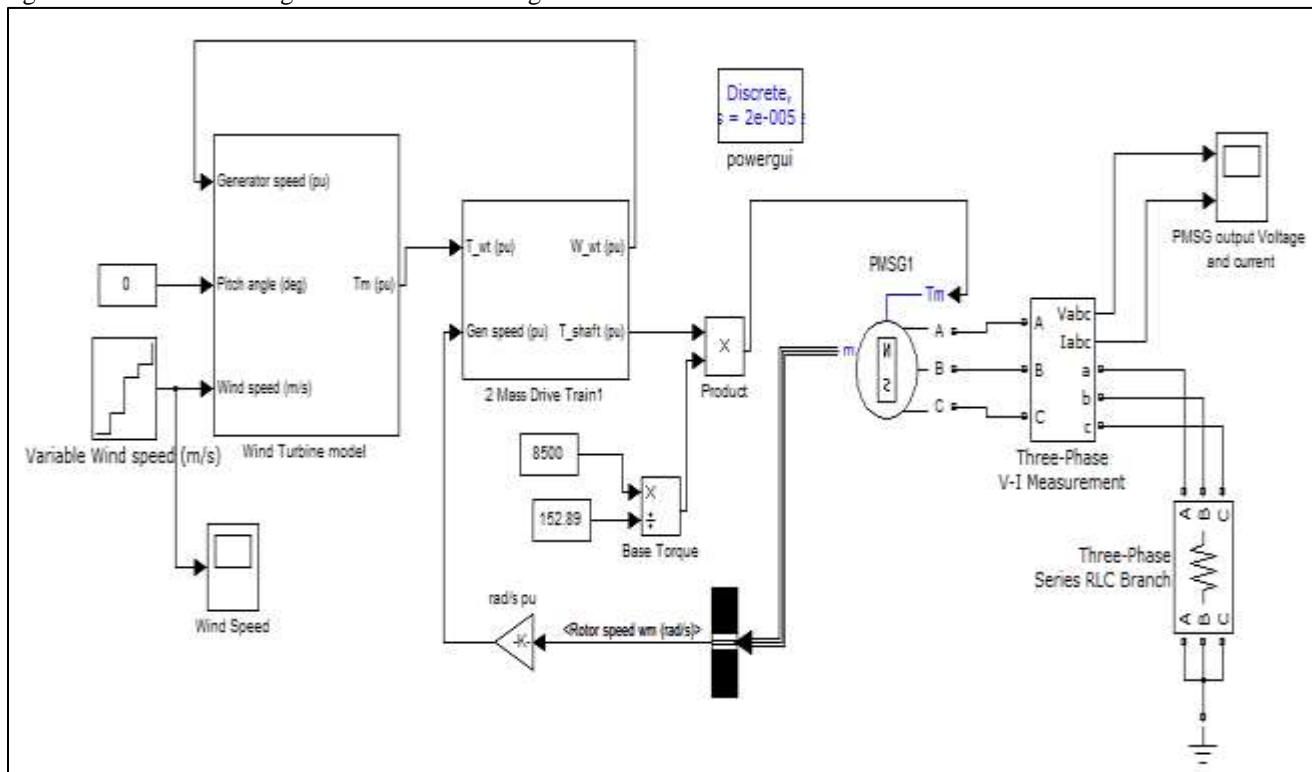

Fig. 5: PMSG connected to variable wind speed profile

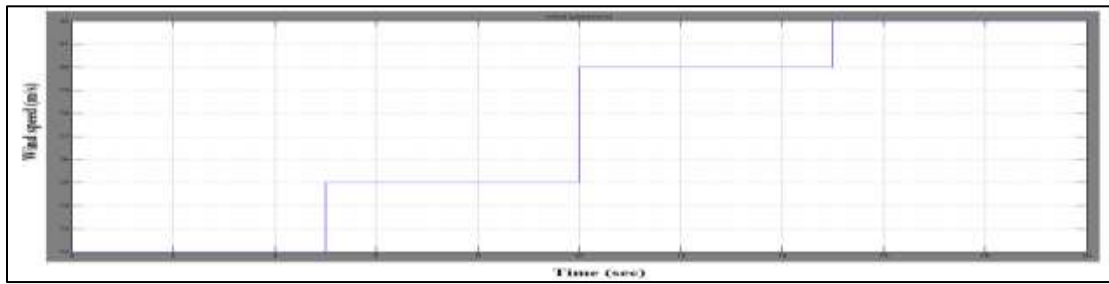

Fig. 6: Variable wind speed profile

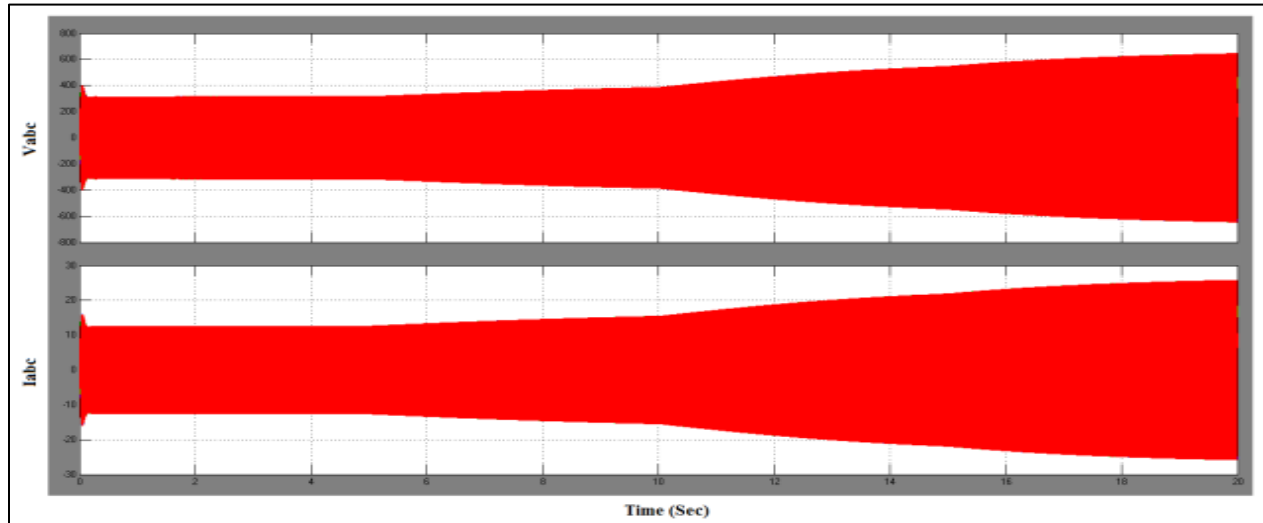

Fig. 7: Output  $V_{abc}$  and  $I_{abc}$  for Variable wind speed profile

## V. CONCLUSIONS

Variable-speed wind turbines are extracted more power than fixed speed wind turbine over a wide range of wind speeds. With a variable-speed operation, it has become possible continuously to adapt the rotational speed of the wind turbine to the wind speed. Fixed speed wind turbine system gives maximum efficiency only at particular one wind velocity, but the variable speed system gives maximum efficiency at each of wind velocity.

The simulation results of both the system show that voltage and current waveform, in fixed speed system for any wind velocity power remain constant, but in variable speed system the voltage & current at low wind speed is low and with the increase in wind speed, voltage & current also increases according to that. The variable speed system is somewhat more complex than the fixed speed system, but this system increase reliability of supply, reduces wastage of power and also gives less fluctuation in output power due to changes in wind velocity.

## ACKNOWLEDGMENT

The authors would like to thank the Electrical Engineering Department of S.N.D college of Engineering for their technical support and cooperation in providing information.

## REFERENCES

- [1] S.S. Murthy, Bhim singh, P.K. Goel & S.K. Tiwari "A Comparative Study of Fixed Speed and Variable Speed Wind Energy Conversion Systems Feeding the Grid" IEEE Transactions on PEDS, 7<sup>th</sup> international conference on Nov. 2007.
- [2] S.S. Murthy, CS Jha, P.S. Nagendra Rao, "Analysis of Grid connected Induction Generators Driven by Hydro/Wind Turbine under realistic system constraints", IEEE/PES 1989.
- [3] J. G. Slootweg S. W Haan, H. Polinder, W. L. Kling, "General Model for Representing Variable Speed Wind Turbines in Power System Dynamics Simulations.", IEEE Trans. on Power Systems 2003, vol. 18, No. 1, February.
- [4] R. Datta and V.T. Ranganathan "A Method of Tracking the Peak Power Points for a Variable Speed Wind Energy Conversion System" IEEE Transactions on Energy Conversion, vol. 18, no. 1, March 2003. pp. 163-168.
- [5] C. N. Bhende, S. Mishra and S. G. Malla, "Permanent Magnet Synchronous Generator-Based Standalone Wind energy Supply system", IEEE Trans. on Sustainable Energy, vol. 2, no. 4, pp. 361-373, Oct. 2011.
- [6] H. Huang C. Mao J. Lu D. Wang "Small-signal modeling and analysis of wind turbine with direct drive permanent magnet synchronous generator connected to power grid", IET Renew. Power Gener., 2012, Vol. 6, Iss. 1, pp. 48-58.
- [7] S. N. Bhadra, D. Kastha, S. Banerjee, "Wind Electrical Systems," Oxford University Press, New Delhi, 2009.