



O MÉTODO DE ALINHAMENTO DE INCLINAÇÃO DOS OBJETOS COM FUNDAÇÕES DE GRANDES TAMANHOS E COM AS CARGAS AUMENTADAS



METHOD OF ALIGNING THE LURCHES OF OBJECTS WITH LARGE-SIZED FOUNDATIONS AND INCREASED LOADS ON THEM

МЕТОД ВЫРАВНИВАНИЯ КРЕНОВ ОБЪЕКТОВ С БОЛЬШЕРАЗМЕРНЫМИ ФУНДАМЕНТАМИ И ПОВЫШЕННЫМИ НА НИХ НАГРУЗКАМИ

SOKOLOV, Nikolai S.^{1, 2*}; VIKTOROVA, Svetlana S.³

¹ Chuvash State University named after I.N. Ulyanov, Department of Construction Technology of Geotechnics and Construction Economics, 15 Moskovskiy Ave., zip code 428015, Cheboksary – Russian Federation (phone: +78352624596)

² OOO NPF "FORST", 109A Kalinin Str., zip code 428000, Cheboksary – Russian Federation (phone: +89050292512)

³ Chuvash State University named after I.N. Ulyanov, 15 Moskovskiy Ave., zip code 428015, Cheboksary – Russian Federation (phone: + 89051987203)

* *Corresponding author*
e-mail: ns_sokolov@mail.ru

Received 06 June 2017; received in revised form 19 November 2018; accepted 20 November 2018

RESUMO

O esquema básico para o cálculo das bases de fundações de grandes tamanhos é atualmente o esquema de uma camada linearmente deformável de espessura finita. A extensa experiência de operação e os resultados das observações de longo prazo de seu assentamento mostram que o assentamento real se mostrou significativamente mais do que os valores calculados pela fórmula de cálculo de assentamento baseada na teoria deste modelo. O material do assentamento real dos objetos construídos em fundações de grandes tamanhos com cargas elevadas mostra que as curvas de assentamento consistem em segmentos lineares e não lineares. O segmento linear do gráfico de assentamento caracteriza o processo de compactação do solo. O aumento das velocidades dos assentamentos no segmento não linear deve ser explicado pelo crescente papel dos deslocamentos horizontais na deformação total da base. O fato que os movimentos horizontais desempenham um papel significativo no assentamento geral da estrutura é confirmado por numerosos estudos das bases sob os tanques e aterros, bem como em experiências de pequena escala. A consideração do deslocamento horizontal permite que os valores de assentamento real e os calculados sejam tão próximos quanto possível.

Palavras-chave: *pressão média, inclinação, placa base, assentamento, camada linearmente deformável de espessura finita.*

ABSTRACT

The basic scheme for calculating the bottoms of large-sized foundations is at present a scheme of a linearly deformed layer of finite thickness. A large operational experience and the results of long-term observations for the subsidence of the foundations show that the actual subsidence of the foundations turned out to be much larger than the calculated values determined by the subsidence of the foundations calculation formula based on the theory of this model. The material of the actual subsidence of the constructed objects on large-sized foundations under increased loads shows that the subsidence curves consist of linear and non-linear sections. Then the settlement speed decreases and the stabilization stage begins. The linear section of

the subsidence graph characterizes the process of soil compaction. The increase in settlement speed in a nonlinear section should be explained by the increase in the role of horizontal displacements in the general deformation of the bottom. The fact that horizontal displacements play a significant role in the overall subsidence of the structure is confirmed by numerous studies of the bottoms under reservoirs and embankments and in small-scale experiments. The account of horizontal displacement allows you to maximize the actual precipitation to the calculated ones.

Keywords: *average pressure, lurch, foundation plate, subsidence, a linear-deformable layer of finite thickness.*

АННОТАЦИЯ

Основной схемой расчета оснований большемерных фундаментов в настоящее время является схема линейно-деформированного слоя конечной толщины. Большой опыт эксплуатации и результаты длительных наблюдений за их осадками показывают, что фактические осадки оказались значительно больше расчетных величин, определенных по формуле расчета осадки основанной на теории этой модели. Материал фактических осадок построенных объектов на большемерных фундаментах при повышенных нагрузках показывает, что кривые осадок состоят из линейного и нелинейного участков. Линейный участок графика осадки характеризует процесс уплотнения грунтов. Возрастание скоростей осадок на нелинейном участке следует объяснить возрастанием роли горизонтальных перемещений в общей деформации основания. То, что горизонтальные перемещения играют значительную роль в общей осадке сооружения, подтверждается многочисленными исследованиями оснований под резервуарами и насыпями, так и в мелкомасштабных экспериментах. Учет горизонтальных перемещении позволяет максимально приблизить фактические осадки к расчетным.

Ключевые слова: *среднее давление, крен, фундаментная плита, осадка, линейно-деформируемый слой конечной толщины.*

INTRODUCTION

Safe and trouble-free maintenance of any object depends mainly on uneven deformation of bottoms and foundations. In this case, there are undesirable displacements of buildings in the form of lurches.

The building's lurch refers to the unacceptable deformation of any building structure, as a result of which some deviation of the symmetry axis of the building from the vertical occurred. Most often, lurches occur in multi-story buildings (Lurie *et al.*, 2017; Albano *et al.*, 2017). The speed of its formation is different, but, as a rule, the problem is detected in the process of constructing. If the rate of a lurch does not reach a critical level, stabilization methods are used. In cases where the structure is already in an emergency condition, one should resort to drastic measures – aligning the lurch of buildings (Lomakin *et al.*, 2018; Tikhonov *et al.*, 2018). Currently, the newest methods of protecting buildings from rolls are developed and effectively used, which are shown below:

1. Washing out of the soil from the bottom of a foundation. This technology based on

drilling of vertical wells in the foundation plate and immersing injectors with seals in them. There are two cavities, external and internal, in each injector. Through the internal cavity of the injector, high-pressure pumps deliver a strong stream of water. Water washes away the soil, and stationary pumps lead it to the surface in the form of pulp through the external cavity of the injector. The supply of water under considerable excessive pressure and removal of the soil occur until the building is completely aligned. Then, hardening solution is supplied (through already drilled holes) under the bottom of the foundation.

2. Freezing of soil. The pipes are lowered in the vertical wells drilled in the foundation, through which cooled kerosene or liquid nitrogen is supplied under the bottom of the foundation. When the soil is frozen to the desired radius, hot water or steam is passed through the same tubes to thaw it. The pulp formed from the soil has no structural connections and when the foundation is settled, it is simply forced out to reach the design position of the foundation; several freezing and thawing cycles should be carried out. When the works on extracting of necessary volume of soil are completed, the soil under the bottom of the foundation is

strengthened by carbonizing.

3. Vibrating-creeping method. It is used in case of occurrence of sandy soil at the bottom. Through vertical wells drilled in the foundation, holes are drilled even lower at the sandy bottom itself. Special vibration equipment creates oscillations at the bottom. As a result of these fluctuations, the sandy soil fills the drilled wells. The crumbled sand is removed through the same working holes, after extracting the vibrator. The actions are repeated until the foundation reaches the design position. Then all the holes are filled with a cement-sand mortar.

4. The method of aligning the lurches of buildings and structures, put up on mat foundations includes the removal of soil under the bottom of the foundation. After removing the soil some trenches are arranged at the bottom of the excavation, they are filled with compacted soil and pillars with supports are installed in the trench. The gaps are left between the bottom of the foundation and the pillars. Secondary excavation is carried out under the bottom of the foundation during its displacement in the direction opposite to the lurch. The gaps between the bottom of the foundation and the pillars are filled partially or completely with the incompressible material, and after aligning of the lurch, hardening of the ground under the pillars supports is made by pumping the fixing solution into the ground.

LITERATURE REVIEW

The fact that horizontal displacements play an important role in overall subsidence of foundation is confirmed by studies in bench conditions with the models of foundations carried out by M.N. Okulova and M.N. Baliuroy (Balura, 1983; Balura, 1975; Balura and Okulova, 1977; Okulova, 1966; Okulova, 1967), as well as in polygon and field conditions conducted by L.A. Shelest (1972; 1975). The most valuable studies in field conditions were carried out in the foundations for the cases of reservoirs and embankments of reservoirs.

Analyzing the results of the research, R. Darragh (1964) came to the conclusion, that when the load on the base of the reservoir increases, a considerable rise in the horizontal displacements of soil is observed.

The studies of P.A. Konovalov and R.A. Usmanov (1983) also revealed a significant effect of horizontal displacements of soil on the rate of

overall subsidence of models and natural reservoirs. The rates of a proportional limit determined by the graphs "subsidence-load" indicate that the curvilinearity of the graph $S=f(P)$ is due to the increasing rates of horizontal displacements of bottom soil.

The close relationship between horizontal displacements of soil and vertical subsidence is indicated by the graphs of their mutual dependence. The linear relationship between them is observed only during the first increments of loading, then the horizontal displacements begin to increase drastically. During the last increments of loading, the increase in subsidence is determined to a large extent by the increase of horizontal displacements. This is confirmed by the results of observations of subsidence of Cubzak-les-Ponts embankments (Magnan, 1978), Kaliks (Holtz and Holm, 1973), King Lin and Tikton (Wilkes, 1972).

We also obtained results similar to those of R. Darragh (1964), Belony (1974), P.A. Konovalova and R.A. Usmanov (1983) etc. Observations of the horizontal displacements at the bottom of one of the objects showed that y-coordinate of the maximum horizontal displacement $Y_{max} \approx 4$ cm is located approximately at a depth of $z \approx 0.2b$. The average subsidence is about $S=8$ cm. The average pressure at the time of the study was $P_{lim}=300$ kPa.

MATERIALS AND METHODS:

In order to establish the regularities of deformation of the foundations and the course of subsidence of large-sized foundations, field studies were conducted on the construction sites, related to the measuring of the subsidence, horizontal displacements of soil, bearing pressures under their soles, and the measuring of pressure in the working reinforcement of the plate. Subsidence of the foundations was measured by geometric leveling of the precise levels and lined invar rods every other month. For this purpose, settlement points were installed on the lower monolithic plate and along the perimeter of the upper monolithic foundation plate 0.5 m above the design elevation.

In the ground on an undeveloped territory, the initial geodesic signs were arranged - deep benchmark, as well as layer-by-layer deep-earth marks. Field studies on observations of horizontal displacements were organized by drilling wells to

the required depth, with a diameter of 120 mm with a drilling rig UGB – 50 with an auger tool. After cleaning the bottom of the well, a casing of 89 mm diameter assembled from separate parts was descended. To avoid siltation of the casing, its lower part was closed with a plug. A polyethylene pipe with an external diameter of 63 mm was then immersed in the casing, assembled beforehand with gas welding. To measure bearing pressures in 1/4 of the bottom area of the lower plate, 36 soil dynamometers of SDCS-7 and SDCS-6BMR types were installed. Bearing pressures were measured by dynamometers of SDCS-7, which are strong electro-acoustic measuring devices. The force in the upper and lower belts of the reinforcement of the lower monolithic plate was measured with the help of 38 string transducers-dynamometers PSAS, deformation of concrete by 21 string dynamometer such as PLDS. Part of the instruments is located at distances of 6.0; 7.5; 3.5; 27.0; 33.0 m from the center of the foundation plate.

Average subsidence of objects Nos 1÷5 on the box-shaped foundation, which is from 20 to 60 cm, does not affect the normal maintenance of the structure. However, with big subsidence, unevenness appears. Uneven subsidence is also caused by the mutual influence of the objects of the foundations and their outbuildings. For the timely taking the steps in the process of construction and maintenance in order to keep the technological equipment in the vertical position (or to maintain the deviation of the vertical axis within the permissible limits), it is necessary to have the results of high-precision geodetic observations of the subsidence of the foundation plate, which can predict subsidence not only during the construction completion, but also during the period of maintenance. In this respect, the logarithmic formula $S=S_0+A\ln(1+Bt)$ (Sokolov, 2017a; Sokolov, 2017b) is a good equation for the prediction of subsidence to stabilize the deformation of the bottom, where S_0 is the subsidence during the construction period; A and B are determined from the curves of the actual subsidence by two points, when $S_1>S_0$. For this, the logarithmic equation is easily solved if we take $S_2=2S_1$ from zero points when $S>S_0$. Depending on the time of the beginning of high-precision geodetic observations, the invar rod counting is done in years or months.

Using the logarithmic formula, it is possible to predict subsidence during a limited time period. With an unlimited increase in time,

the value of Napierian logarithm goes to infinity. After 3-5 years, observations of subsidence should be repeated, and parameters A and B should be revised. The results of monitoring of the subsidence of box-shaped foundation object Nos.1÷4. are given in articles (Sokolov, 2017a; Sokolov, 2017b; Bugrov and Golubev, 1983;). The data of the observations carried out during the period from 1977 till present, which was dedicated to foundation plates subsidence of the objects, show a fairly good convergence with the results of the actual subsidence, while the discrepancy between the actual and predicted subsidence is about 2%. Table 1 below shows the predicted logarithmic dependencies for these 4 objects.

RESULTS AND DISCUSSION:

In many cases, it is to be expected that actual or predicted uneven subsidence will be greater than the permissible subsidence from the condition of normal maintenance of the equipment. In this case, the lurch is improved or its further growth is stabilized with counterweight mounted on the side the opposite to the lurch. Thus, for example, a counter-lurch of the equipment body was set at 2.8 mm in diameter of the main connector of the object No. 1 at the end of January 1983 (Figure 1). The direction of counter-lurch vector is $\alpha = 160^\circ$. Also, for the object No. 2, counter-lurch was set strictly along axis 2 ($\alpha = 180^\circ$), while counter-lurch value was 4 mm (Figure 2). The time of the rigid fixing of technological equipment of both objects coincides with the time of counter-lurch imparting. The results of high-precision geodetic observations indicate the correctness of the installation of the positions of technological equipment, which are currently within the permissible value of the deviation of the axis of the object from the vertical.

Counterweight for the correct installation of equipment was mounted on the object No. 3 on the side of the outbuildings (Figure 3). Again, the results of high-precision geodetic observations suggest stabilization of the lurch and the correct position of the vertical axes of both objects. For the time being, subsidence and lurches of box-shaped foundations of the objects Nos.1÷4 (Figures 1, 2, 3) have been studied for a long time. Deflections of the foundation plate of the object No. 5 (Figure 4); bearing pressures under the bottom of the foundation, concrete stress and reinforcement stress of the foundation

of the object No. 6 (Figures 5, 6, 7).

The analysis of subsidence and lurches shows that there are two distinct sections on the graphs - linear and nonlinear. The linear section becomes nonlinear at a medium pressure at the bottom $P_{limt} = 250\div 300$ kPa. A lurch of foundations appears even under small loads and its value is very small. From the moment, corresponding to subsidence graph transition to the nonlinear section, the lurch curve also changes linearity, namely, lurch speed increases. From the same moment, the direction of lurch is changed in the opposite direction.

Analysis of the study results of bearing pressures at the bottom, reinforcement stress, reinforcement deformations and concrete stress of lower monolithic plate of the foundation of object No. 6 (Figures 5, 6) allows us to conclude the following. Lower foundation plate is buckled by the central part upwards due to the effects of bearing pressure described above. This is confirmed by the fact that in the further stages of constructing, reinforcement stress practically does not increase. For example, at constructing stage, when average pressure on the central part of the bottom of lower plate reached $P_{limt}=664$ kPa, reinforcement stress of bars installed in the span of the plate was significantly less than $\sigma = 38,600$ kPa stress previously occurred at the same pressure value. A similar phenomenon is observed when considering the indications of dynamometers installed in the geometric center of the plate and at a distance of 6 m from the center under the wall, that is, they decreased noticeably in other reinforcement bars. The reason for this was intensive constructing of technological equipment. Due to the loading of the middle part of the foundation, the lower plate's buckle has decreased. Accordingly, the reinforcement stresses of the plate decreased too.

Measuring instruments of concrete deformations provide with a picture corresponding to deformation of the plate because of soil bearing pressures and loading of airtight volume. As the load increases, both deformation and stress in concrete do not increase, in comparison with those at the ground pressure on the central part of the plate bottom equal to $P_{limt}=430$ kPa, but they decrease.

Field studies of deflections of the lower plate of the box-shaped foundation of the object No. 5 (Figure 4) successfully correspond to the results of bearing pressures measurements, reinforcement stress, deformations and concrete

stress on the object No. 6. Thus, it can be concluded that because of the large sizes of the foundation plate, horizontal displacements of the soil in the central part of soil mass under the bottom of the plate are not possible. Therefore, this part of the foundation works under conditions of uniaxial compression. A compacted zone is formed here. Around this zone, the soil moves horizontally beyond the base of the basement, which explains the shape of the bearing pressure diagram at a significant pressure.

The entire process of bottom deformation occurs due to preferential compression of upper layers of the bottom. This is clearly demonstrated by the results of observations of the layer by layer deformations of the bottom of the examined objects (Baimakhan *et al.*, 2016; Sokolov, 2017a; Sokolov, 2017b) and also large-scale foundations and other structures. Consequently, foundations bottoms (Sokolov, 2017a; Sokolov, 2017b) operate according to the scheme of a linear-deformable layer of finite thickness.

If there is an overload that prevents horizontal displacement of the bottom soil, then coordinate of the bearing pressures increase along the edge of the plate (for all objects, except for objects Nos. 1 and 2). The height of the compacted zone is equal to the thickness of a linear-deformable layer of finite thickness. In connection with the above, the method of lurch aligning of the foundations of objects Nos. 1-5 by means of counterweight was recommended (Figures 1-3).

To stabilize the growth of the uneven subsidence of the foundation of the object No. 1 in November-December 1983, the urgent load of 5,780 kN was placed on the foundation console on the opposite side of the lurch direction. To speed up the process of stabilizing the increase of the lurch, adjustable set-on weight is added in sectors A and B on both sides of axis 2 with a weight of about 30,000 kN (Figure 1). After these measures have been taken, the increase of the lurch was stopped.

To reduce the rate of lurch increase of the object No. 2 (Figure 2), an emergency weight of 5,800 kN, as well as set-on weights of 51,000 kN, were added to the sectors A and B, so that the lurch increase was stopped. At present, the subsidence of the foundations Nos. 1 and 2 are stabilized.

The lurch increase of the object No. 3 (Figure 3) was also stopped with the set-on

weights device on the side of the engine room: 17600 kN in November 1984, 3,750 kN in March 1985, 18,700 kN in September-October 1985. In 1999 the lurch is 120 mm or $i=0.0018$. The same effect was achieved on objects No. 4 and No. 5. The results of long geodetic observations of subsidence of foundations under increased loads confirm that the lurch correcting is the right choice.

CONCLUSIONS:

Field studies of vertical and horizontal deformations of bottoms and foundations of large-sized foundations under increased loads, as well as bearing pressures under their bottoms and reinforcement stress are given in this article. Measurements of subsidence of the foundations were taken by the 1st class geometric leveling with the help of high-precision levels and lined invar rods every other month. The results of field studies of 6 objects enabled the development and implementation of their further safe maintenance. The entire process of deformation of the bottom occurs due to the preferential compression of the upper layers of the bottom. It is established that bottoms of foundations work according to the scheme of a linear-deformable layer of finite thickness.

REFERENCES:

1. Albano, F., Caten, C.TEN, Anzanello, M., *Periódico Tchê Química*, **2017**, 14(27), 30-38.
2. Baimakhan, A.R., Rysbayeva, A.K., Seinassinova, A.A., Rysbayeva, G.P., Kulmagambetova, Z.K., Aliyeva, A.M., Baimakhan, R.B. *International Journal of Applied Engineering Research*, **2016**, 11(12), 7698-7701.
3. Balura, M.V. *PhD Thesis*, Platov South Russian State Polytechnic University, Novocherkassk, Russian Federation, **1975**.
4. Balura, M.V. *Studies in building mechanics and building constructions*, Tomsk: Publishing house of Tomsk University, **1983**, 41-45.
5. Balura, M.V., Okulova, M.N. *Bases and Foundations of buildings and structures in the construction of Tomsk*, Tomsk: Publishing house of Tomsk University, **1977**, 36-41.
6. Belloni, L.A., Garassini, L.A., Iamiolkowski, M. *Conference on Settlements of Structures*, Cambridge, England, **1974**, 323-328.
7. Bugrov, A.K., Golubev, A.I. *Danube-European Conference on Soil Mechanics and Fundamental Constructions*, Chisinau, Moldova, **1983**, 203-207.
8. Darragh, R.D. *Journal of Soil Mechanics & Foundations Div*, **1964**, 90, 303-329.
9. Holtz, R.D., Holm, G. *Belastningaforsok pa svartmoka. Internal Report to the National Swedish Road Board*, Linköping: Swedish Geotechnical Institute, **1973**.
10. Konovalov, P.A., Usmanov R.A. *Danube-European Conference on Soil Mechanics and Foundation Engineering*, Chisinau, Moldova, **1983**, 107-112.
11. Lomakin, E.V., Lurie, S.A., Rabinskiy, L.N., Solyaev, Y.O. *Doklady Physics*, **2018**, 63(4), 161-164.
12. Lurie, S.A., Solyaev, Y.O., Lizunova, D.V., Bouzник, V.M., Menshykov, O. *International Journal of Heat and Mass Transfer*, **2017**, 109, 511-519.
13. Magnan, J.-P., Mieussens, C., Queyroi, D. *Revue Francaise de Geotechnique*, **1978**, 5, 23-26.
14. Okulova, M.N. *Bases, Foundations and Mechanics of Soils*, **1966**, 4, 5-8.
15. Okulova, M.N. *PhD Thesis*, the Ural State University, Sverdlovsk, Russian Federation, **1967**.
16. Shelest, L.A. *PhD Thesis*, the Ural State University, Sverdlovsk, Russian Federation, **1975**.
17. Shelest, L.A. *Proceedings of NIIOSP*, **1972**, 63, 215-218.
18. Sokolov, N.S. *Housing Construction*, **2017a**, 9, 25-28.
19. Sokolov, N.S. *Housing Construction*, **2017b**, 5, 34-37.
20. Tikhonov, I.N., Blazhko, V.P., Tikhonov, G.I., Ghazaryan, V.A., Krakowsky, M.B., Tsyba, O.O. *Housing Construction*, **2018**, 8, 3-10.
21. Wilkes, P.F. *ASCE Specialty Conference on Performance of Earth and Earth Supported Structures*, Lafayette, England, **1972**, 29-63.

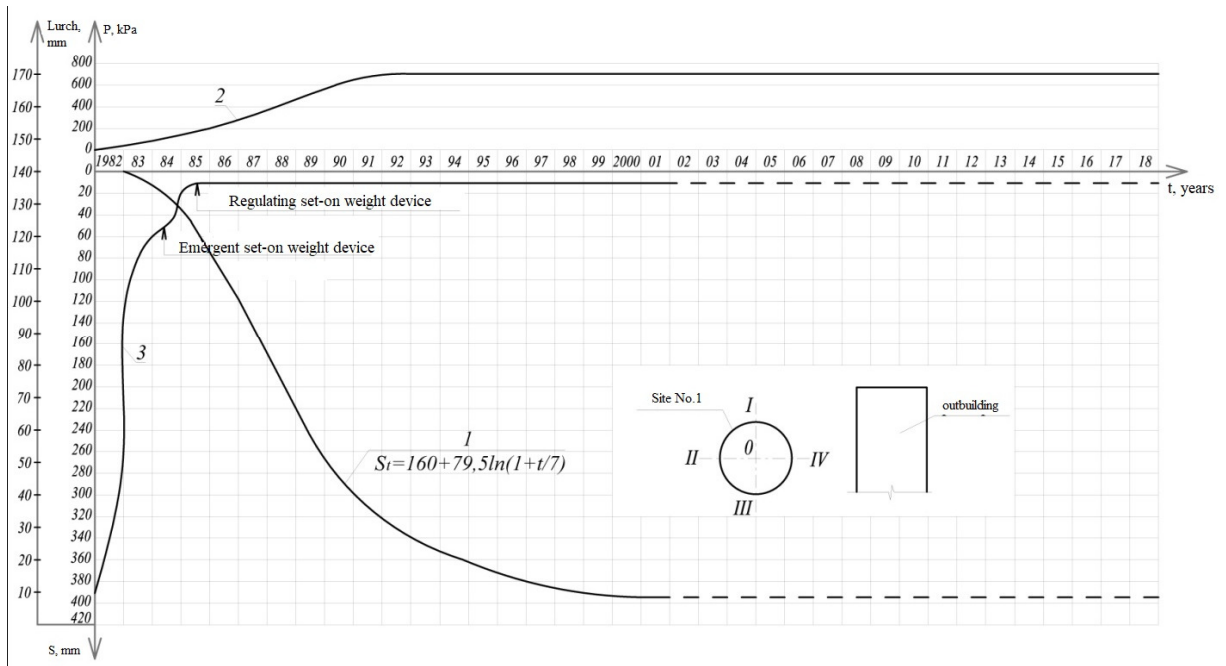

Figure 1. Object No. 1 Chart 1 – average subsidence; 2 – increase in mean pressure; 3 – final lurch.

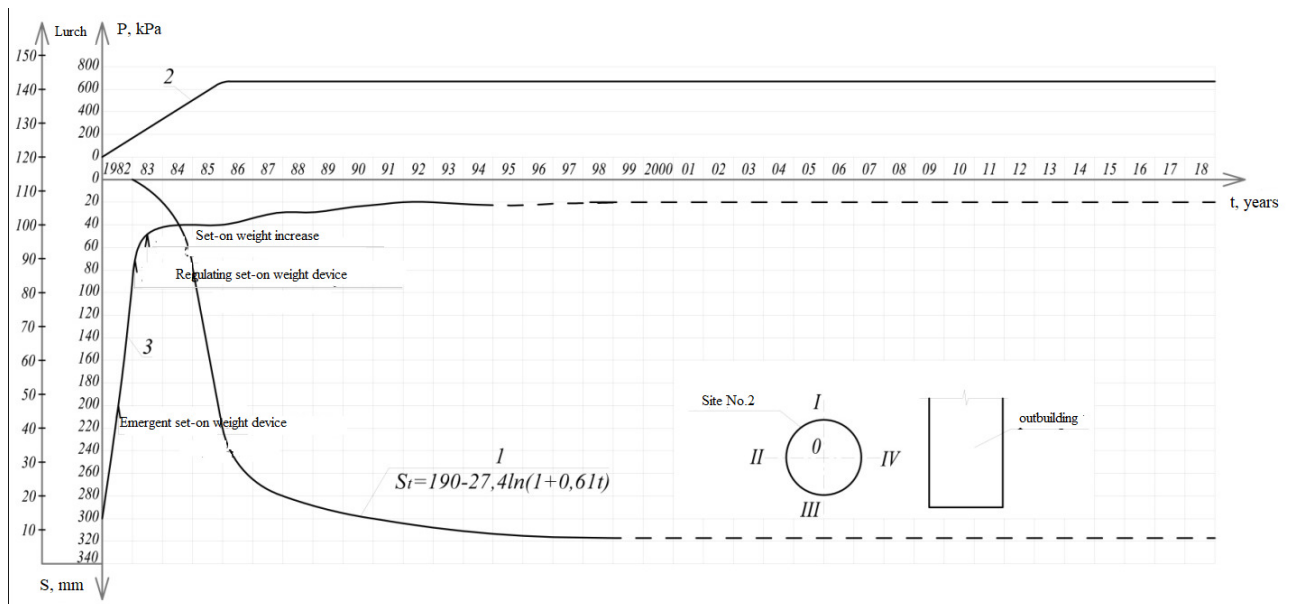

Figure 2. Object No. 2 Chart 1 – average subsidence; 2 – increase in mean pressure; 3 – final lurch.

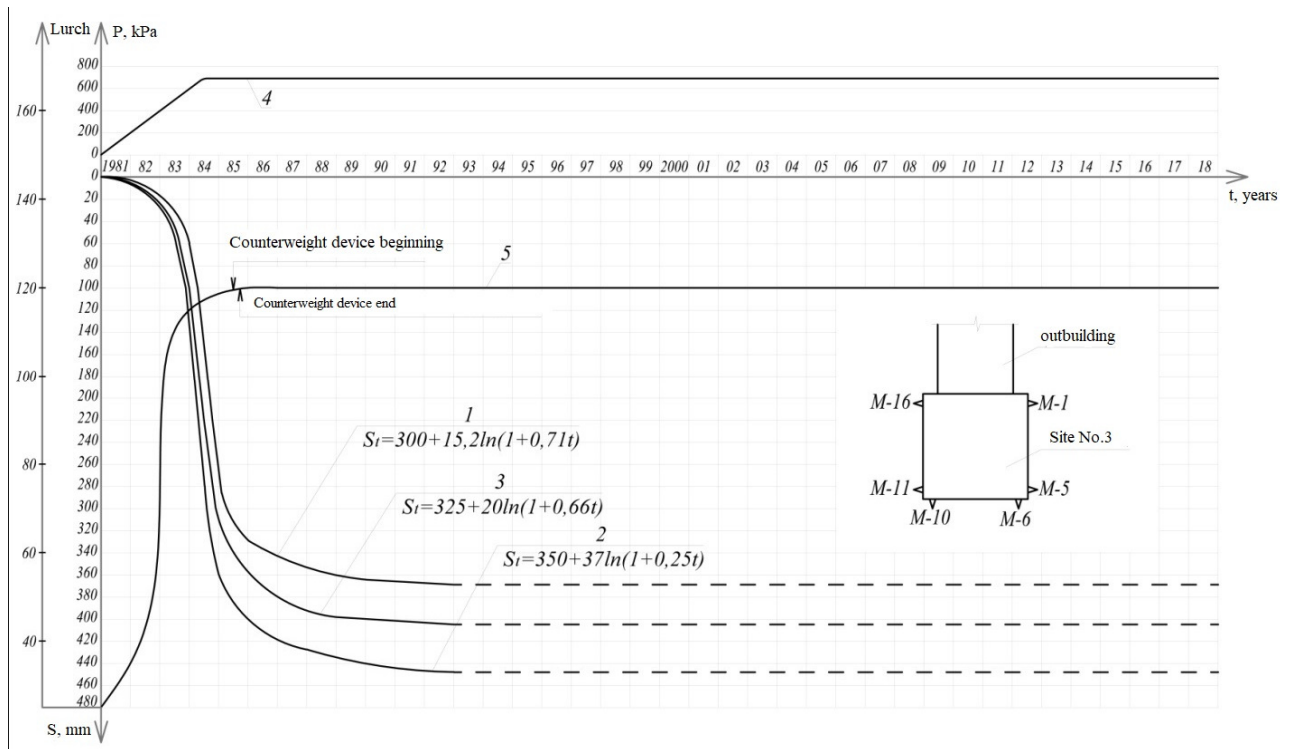

Figure 3. Object No. 3 Graphs 1 – minimum subsidence; 2 – maximum subsidence; 3 – average subsidence; 4 – increase in mean pressure; 5 – final lurch.

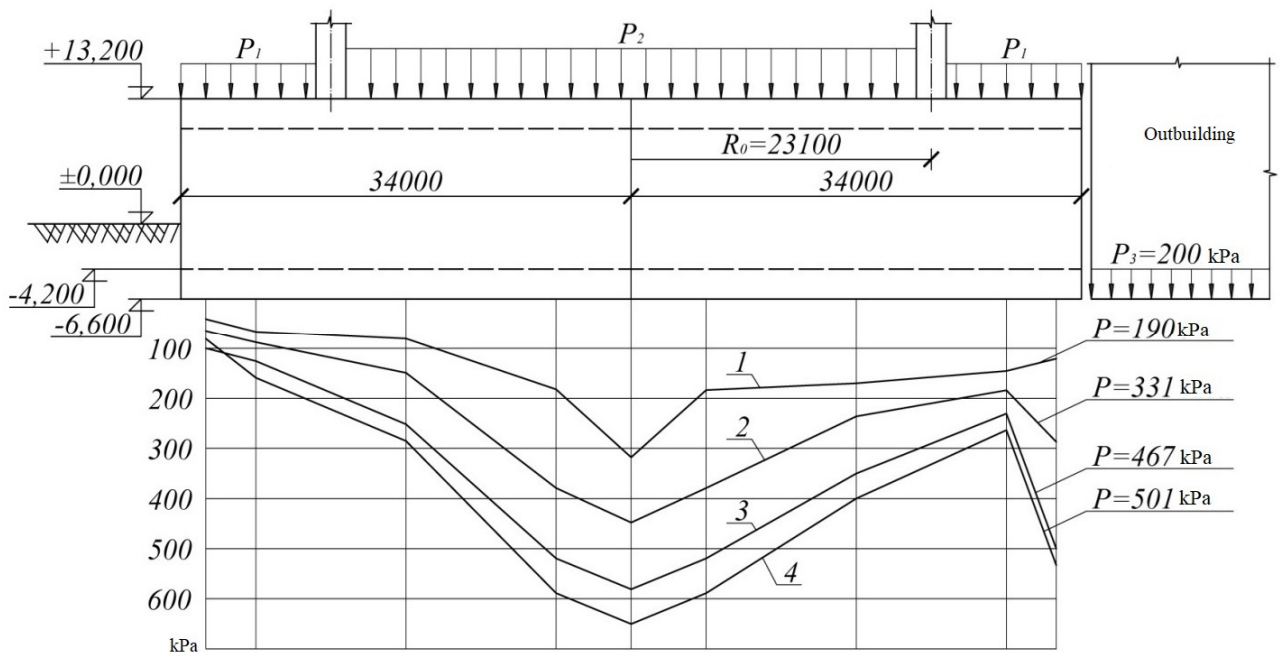

Figure 4. Object No. 5 Curve of reaction pressures at various mean pressures.

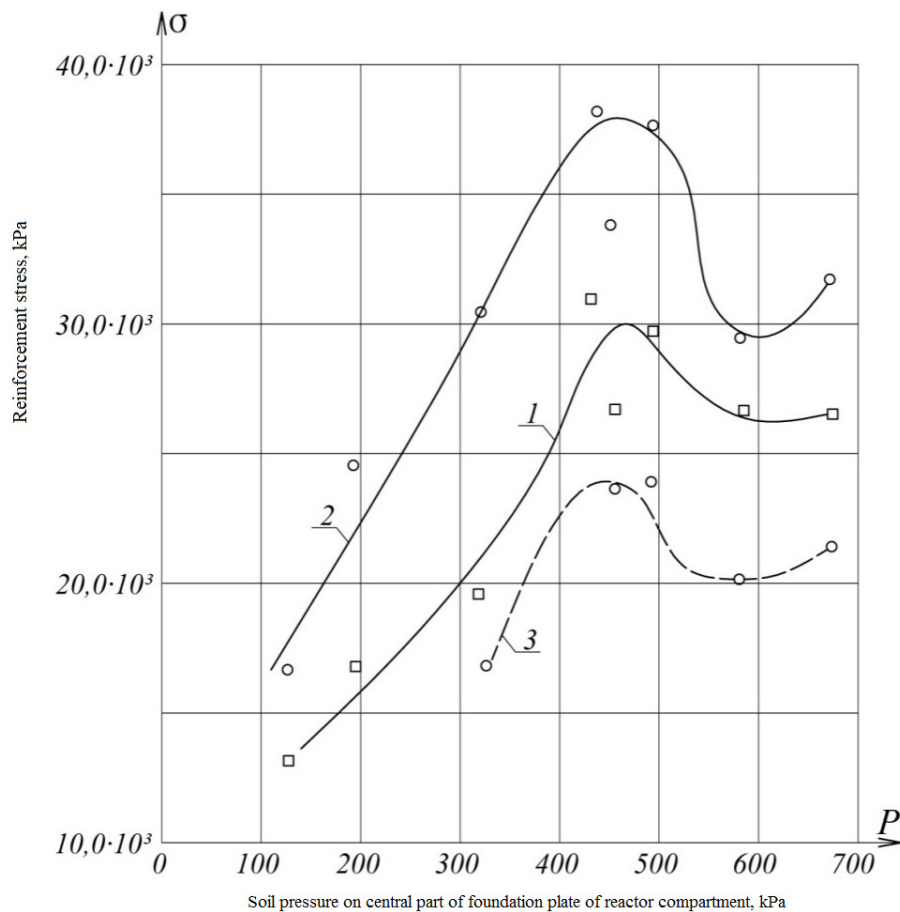

Figure 5. Object No.6 Dependence of tensile stresses in working reinforcement of the upper belt of the lower plate of the box-shaped foundation on the reaction pressure of the soil on the central part. 1 – Stresses on dynamometers arranged in the geometric center of the plate; 2 – Stresses on dynamometers at a distance of 6.0 m from the center of the plate; 3 – Stresses on dynamometers at a distance of 6.0 m from the center under the wall.

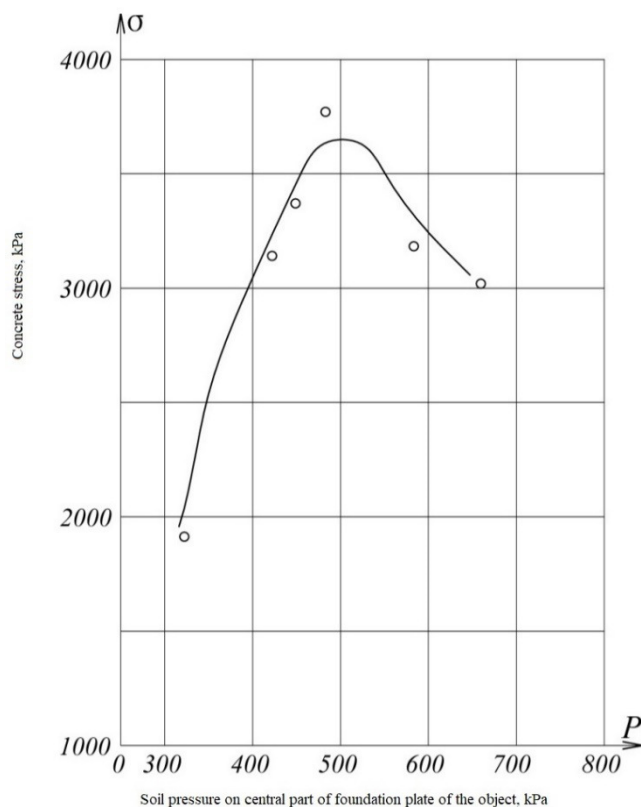

Figure 6. Object No. 6. Dependence of tensile stresses in the concrete of the upper zone of the lower plate of the box-shaped foundation on the value of the reaction pressure on the central part of the bottom.

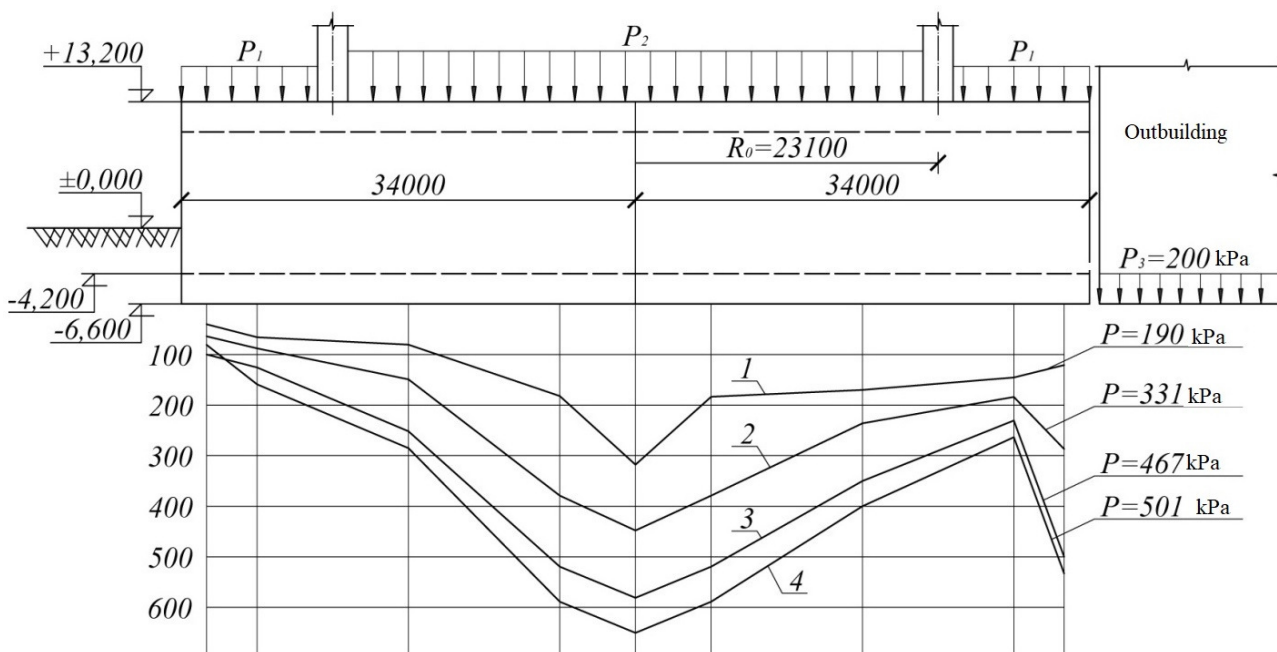

Figure 7. Facility No. 6. Deflections of the bottom plate of the box-shaped foundation at different mean pressures P_{limt} :

1 – the lower plate; 2 – the top plate; 3 – load from the outbuilding P_1 ; 4 – load from technological equipment P_2 ; 5 – zone of process equipment.

Table 1. Forecast of the foundations of the objects in logarithmic dependence
 $S=S_0+A\ln(1+Bt)$

S. No	Name of the observation object	Predicted subsidence, S_t			Notes
		Max.	Min.	Mean value	
1	Object 1	$220+103,6\ln(1+0.11t)$	-	$160+79,4\ln(1+t/7)$	1. Coefficients A and B are determined by actual subsidence curves; 2. Time t – in months
2	Object 2	-	-	$190+27,4\ln(1+0.61t)$	
3	Object 3	$350+37\ln(1+0.25t)$	$300+15,2\ln(1+0.71t)$	$325+20\ln(1+0.66t)$	
4	Object 4	$410+25,7\ln(1+0.53t)$	$370+17,4\ln(1+0.86t)$	$404+23,4\ln(1+0.5t)$	